

Quick Start Guide

Before Installing the Valve

1. To mount the valve on the actuator, place the O-ring on the valve in the circular indentation around the stem.
 2. Use a thin metal object that fits in the valve stem groove to turn the valve and adjust it so that it is aligned with the actuator.
 3. Once the valve is aligned and in place, put the clip on the four pins such that the curve is on the inside of all four posts.
 4. Make sure the Water Control Panel wiring matches the wiring guide on page 2 for single actuator or page 3 for dual actuator. **To access the board,** remove the four screws on the front of the Water Control Panel, remove the bottom and flip the front panel so that the back is facing up.
 5. Plug the Water Control Panel into a standard outlet. **KEEP FINGERS AND OTHER OBJECTS AWAY FROM VALVE TO AVOID INJURY.** You should hear the actuator turn the valve one full cycle.
 6. Test the actuator by removing the rubber stops at both ends of the valve and checking to see the valve position. The indicator lights on the Water Control Panel should show the correct current position of the valve.
 7. Change valve position by pressing the UNLIT "OPEN" or "CLOSE" button. Press the UNLIT indicator, either "OPEN" or "CLOSE", whichever one does not have a LIT light next to it to tell the actuator to perform one-half cycle.
-  **KEEP FINGERS AND OTHER OBJECTS AWAY FROM VALVE TO AVOID INJURY.**
8. Visually verify that the valve has changed position.
 9. Repeat steps 10-11 a few times by pressing the alternating UNLIT button "OPEN" or "CLOSE" to test and exercise the valve and actuator.
 10. You are now ready to install the valve. Please refer to the "Valve Installation" section of the Instruction Manual for detailed instructions for various methods of installation.

Installing and Testing Sensors

Hardwired Sensor Probes

1. To install hardwired sensor probes (WPSC), first ensure that power is disconnected to the Water Control Panel.
2. Open the case for the Water Control Panel and note the side circuit board with one long terminal strip going the full length.
3. Wire the desired number of sensor probes into the terminal strip matching the leads of the wire with the paired off terminals as marked by the writing on the circuit board.
4. If the wires are in the wrong terminals, the sensor probe will not work.
5. Once you have wired the desired number of sensor probes into the terminal strip, close the case and replace the screws.
6. Plug the Water Control Panel into a standard outlet and wait for it to beep indicating it has finished its boot up sequence.
7. SHORT the sensor probes with a metal object to have the Water Control Panel recognize them. The lights will remain on showing which sensor probes the system recognizes and will flash when something is wrong.
8. Test each sensor probe by shorting it until the Water Control Panel display shows that the probe has shorted and then removing the short and waiting for the display to go back to normal. (5-10 seconds)
9. Test each sensor probe by getting it wet, checking that the valve did close and the alarm did sound.
10. Between each sensor probe wet test, first silence the Water Control Panel AFTER the valve has finished closing by pressing any button once, then remove the source of wetness and completely dry off the sensor probe.
11. Press the "OPEN" button once and then wait for the solid "MODE" light to turn off before pressing "OPEN" again to open the valve and continue.
12. Repeat steps 8-11 until all sensor probes have been tested.

Wireless Sensors

1. Before installing the wireless sensors, keep them all near the Water Control Panel. Ensure the sensors have batteries installed or are plugged into a standard outlet nearby for adding into the system. Valve must be open for programming where the display reads "WATERCOP NORMAL".
2. On the Water Control Panel, press the "MODE" button twice waiting a few seconds between each button press until the display reads "DEVICE ADD / PRESS NEXT →".
3. Press "CLOSE", which is indicated by the "NEXT →" to put the Water Control Panel into add mode. The display should read, "DEVICE ADD / DEV#_ ID=".
4. Take one sensor and short the probe to add the sensor into the system. For Dual Sensors, only one probe needs to be shorted to add the sensor into the system. For Temperature Sensors, short the moisture probe rather than the temperature sensing probe.
5. Once the sensor has been added into the system (which is indicated by the Water Control Panel beeping and reading "DEVICE STATUS / SEN#_ SHORT1") wait until the display reads "DEVICE STATUS / SEN# __ OK!".
6. Press "MODE" once to go back to the "DEVICE ADD" display. (*If time has passed and the display reads "WATERCOP NORMAL"; go back to step 2.)

7. Repeat steps 3-6 for each sensor to add them all into the system.
8. At the same time, be sure to number them according to the order they are added into the system. You'll need this to record them in the Sensor Location Log (included) when you put them in location.
9. When all of the sensors have been added into the system, you are ready to test them.
10. Test the sensors by individually getting them wet and waiting until the alarm goes off and closes the valve.



KEEP FINGERS AND OTHER OBJECTS AWAY FROM VALVE TO AVOID INJURY.

11. Silence the Water Control Panel by pressing any button once AFTER the valve has finished closing.
12. Remove the source of wetness from the sensor probe and dry it off completely.
13. Wait until the display reads "!ALARM! SEN#__ OK".
14. Press the "OPEN" button to open the valve and continue.
15. Repeat steps 10-14 for each sensor probe.
16. Now you can install the wireless sensors following the "Installing the Wireless Sensors" and "Placement of Wireless Sensors" sections of the Instruction Manual to properly install the sensors.

WaterCOP Pro Single Actuator Wiring

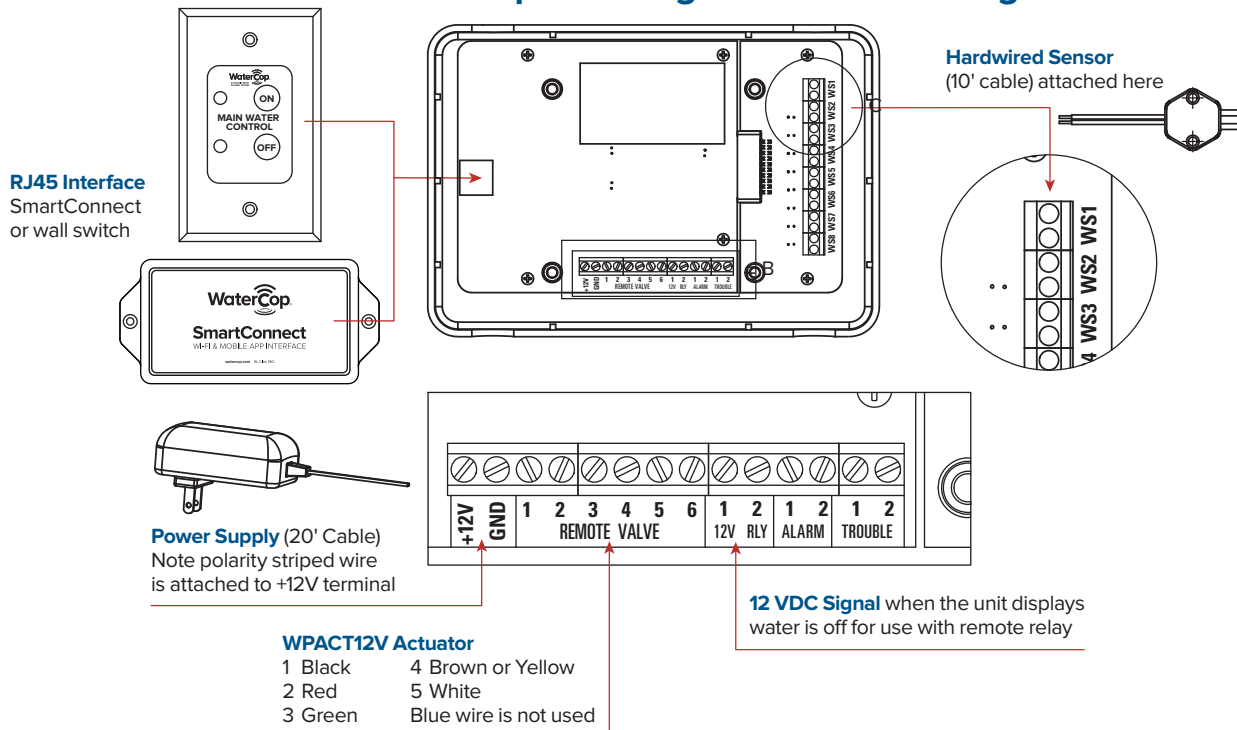

WaterCop Pro Dual Actuator Wiring

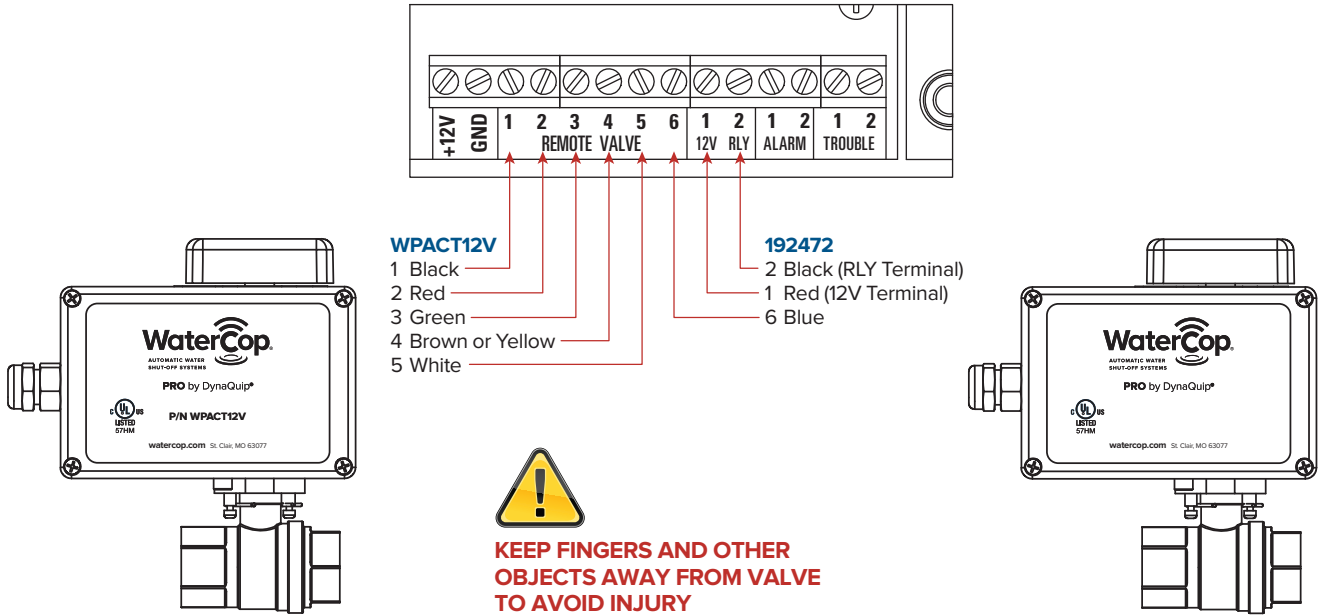

Relay Wiring to Terminate Power

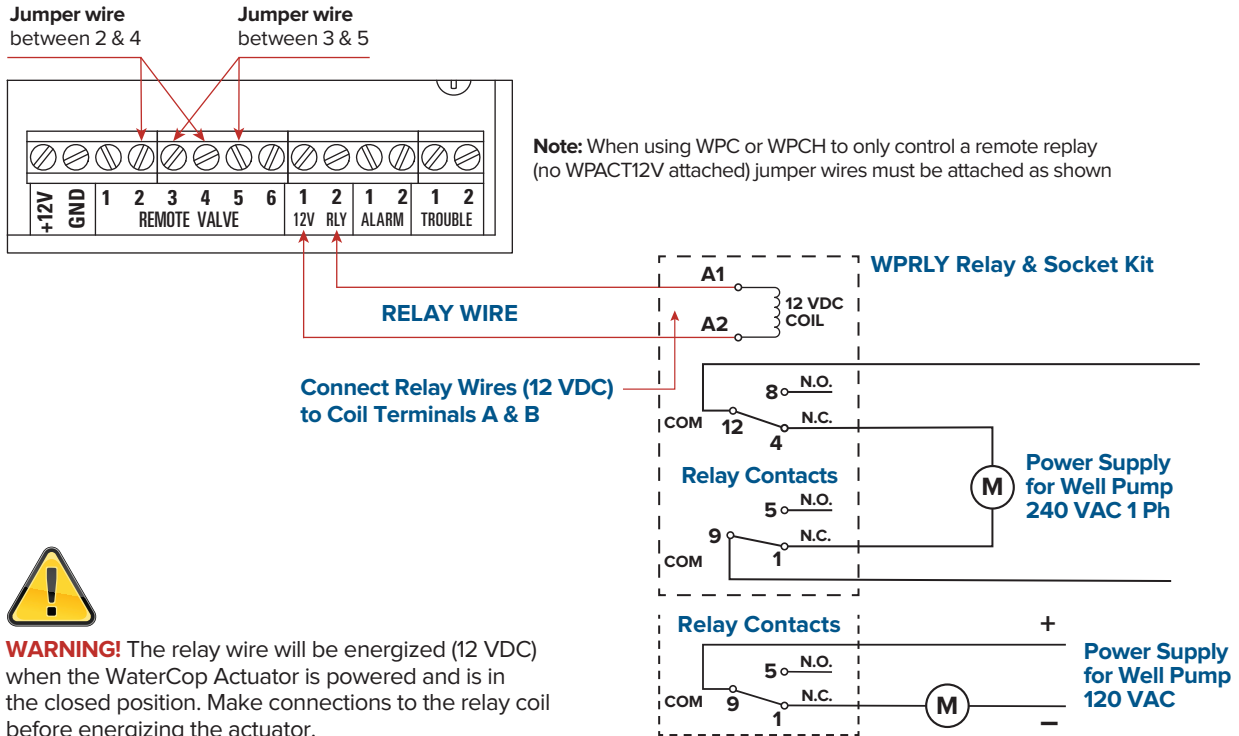

WaterCop Interface to Security Panels

Pro Interface Contacts

1-----8

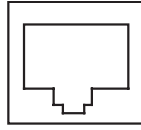

RJ45 Socket

- 7 Brown/White (5VDC)
- 5 Blue/White (to close)
- 6 Green (to open)

CAT5-E

- 3 Green/White
- 4 Blue
- 2 Orange

Input Signals from Security Panel to Change Valve Position

Apply momentary dry contact closure between lines 5 and 7 to close the ball valve.

Apply momentary dry contact closure between lines 6 and 7 to open ball valve.

Output Signals to Security Panel for Valve Position

Dry contact closure between lines 3 and 4 indicates valve open.

Dry contact closure between lines 2 and 3 indicates valve closed.

WPC/WPCH Output Signals to Security Panel

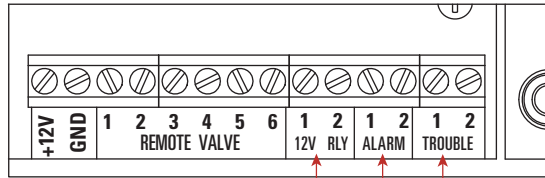

Dry contact closure signal to security panel during alerts

An alert is a problem with a sensor. A probe is shorted, open or low battery is detected. Water is not shut off.

Dry contact closure signal to security panel during alarms

An alarm is a water shut-off due to a sensor detecting water and activating the system. There is no alarm signal if the valve is closed by an input from the security panel or the WaterCop panel.

12 VDC Signal when the unit displays water is off for use with remote relay



PRO by DynaQuip®



To order or for additional information, visit watercop.com or call 800-545-3636.